

Technical Specification

Monorail

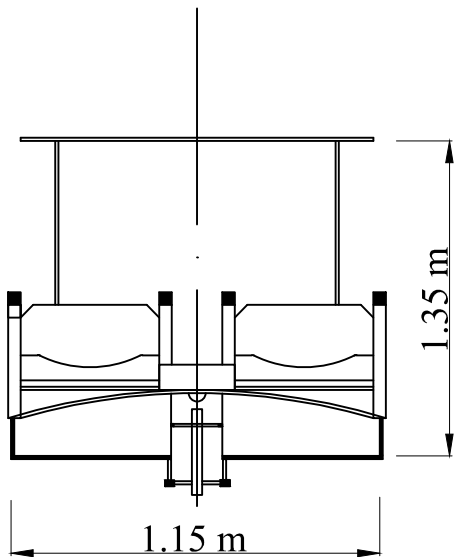
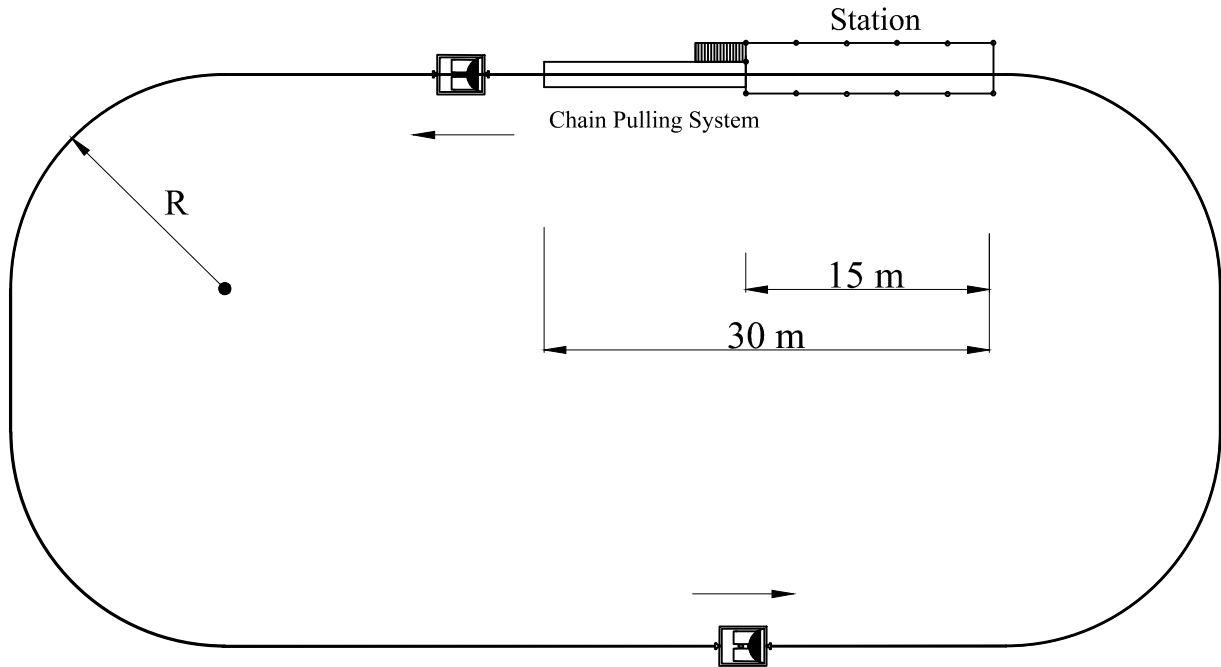

Technical Data

Seats	20-30
Capacity(pph)	300-450 pers/hr
Minimum Passenger Height (cm)	120 cm
Power	3Ph/380V/50Hz/15KVA
Track Figure	Selective
Line Height	2.5-5 m
Overall Length	180-400 m
Radius of curve	Min 7m
Number of cabins	10 (Ext. to 15)

